



# Series 3000 Cooling Tower

## TABLE OF CONTENTS

---

**B9**    **SERIES 3000 COOLING TOWER**

---

**B13**    **XE-SERIES 3000 COOLING TOWER**

---

**B15**    **BENEFITS**

---

**B17**    **CONSTRUCTION DETAILS**

---

**B19**    **CUSTOM FEATURES & OPTIONS**

---

**B32**    **ENGINEERING DATA**

---

**B43**    **STRUCTURAL SUPPORT**

---

**B45**    **ALTERNATIVE STRUCTURAL SUPPORT**

The NEW Series 3000 Cooling Tower once again redefines the cooling tower industry with expanded selection flexibility and capacity increases of up to 16%. The NEW Series 3000 Cooling Tower provides an extremely efficient solution for all your application needs. Transcending an already superior product the NEW XE-Series 3000 is tailored for projects that require extreme efficiency from the cooling tower. The XE-Series units are at least two times more efficient than the minimum requirements established in ASHRAE Standard 90.1 - 2013.



# BAC's Series 3000: The Industry Standard

Large Range of CTI Certified Capacities  
171 to 1,352 Nominal Tons in a Single Cell  
Up to 4,500 USGPM for Process Applications

Industry  
Leading  
Energy  
Efficiency

Most Reliable  
Year-Round  
Operation

Easiest to  
Maintain

Variety of  
Materials of  
Construction

Flexible  
Configurations



# The NEW Series 3000 Cooling Tower

The NEW Series 3000 Cooling Tower continues its industry leading tradition. With expanded selection flexibility and a capacity increase of up to 16%, the Series 3000 Cooling Tower provides an extremely efficient solution for all you application needs.

## > Reduced Energy Consumption

- ▶ Most efficient cooling tower in the industry
- ▶ Up to a 16% increase in capacity
- ▶ Exceeds ASHRAE 90.1-2013 efficiency requirements

400-Ton Example:	Series 3000	Competition	Competition
Fan HP	20	30	40
Footprint (L x W x H)	8.5' x 18' x 12'	8.5' x 18' x 12'	8.5' x 18' x 12'
Nominal Tons	400	386	423

### 400-Ton Example: Annual Operating Cost for a 20, 30, & 40 HP

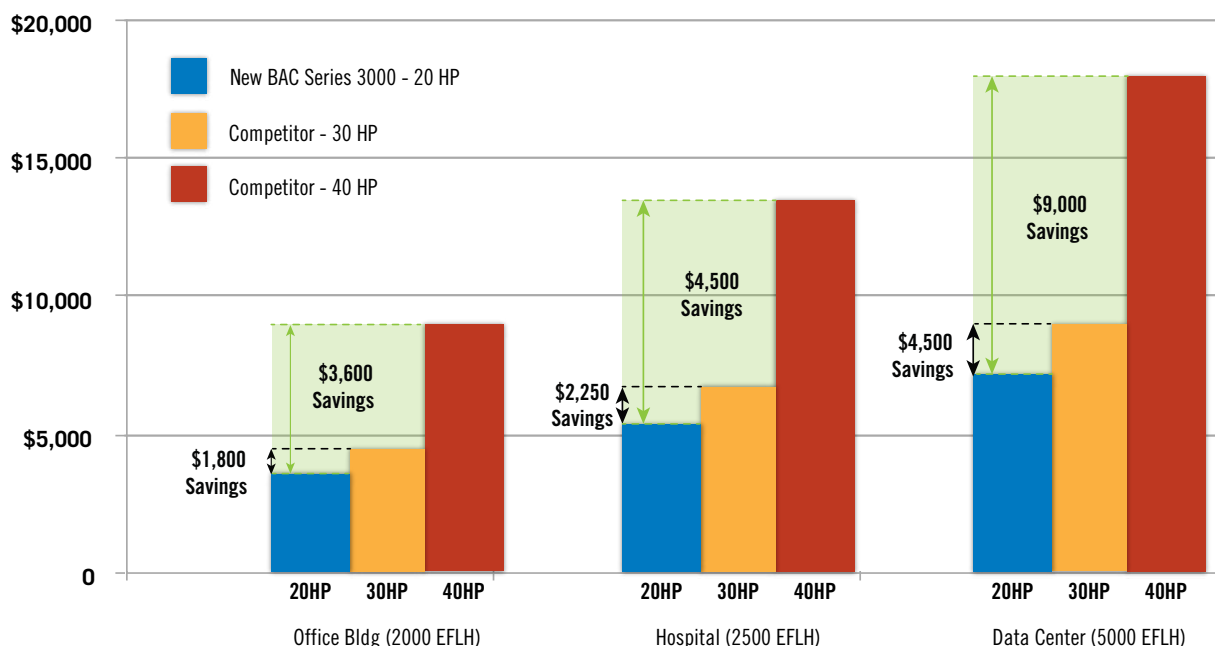

Energy Cost Savings Based on a 400-Ton System (\$0.12 kWh)



## > Reliable Year-Round Operation

- ▶ Superior winter operating performance
- ▶ BALTIDRIVE® POWER TRAIN Fan System
- ▶ Rigid frame construction
- ▶ Meets wind and seismic requirements of the International Building Code (IBC)

## > More Selection Flexibility

- ▶ 31 new models
- ▶ 3 new box sizes
- ▶ 69 XE-Series 3000 Cooling Tower models are available in a full array of box sizes

## > Enhanced Payback Analysis

- ▶ Provides alternative selections based on energy savings and minimum payback
- ▶ User-defined life-cycle cost inputs
- ▶ XE-Series models featured in selection program

## > Easiest to Maintain

- ▶ Direct access to:
  - Cold water basin
  - Hot water basin
  - Drive system
- ▶ Patented hygienic cold water basin
- ▶ Factory assembled access options available for ease of maintenance



New Series 3000 Cooling Tower



Enhanced Product Selection Software



Factory Pre-Assembled Platforms

# XE-Series 3000

The XE-Series 3000 Cooling Tower is the newest addition to BAC's cooling tower portfolio. It is tailored for projects that require an extremely efficient unit to minimize energy costs, reduce sound levels, and contribute to LEED® Certification Points. XE-Series 3000 Cooling Towers are at least two times more efficient than the minimum requirements established in ASHRAE Standard 90.1 - 2013.



## Lowest Operating Costs

- ▶ 37.5% reduction in operating costs for a 500-Ton system
- ▶ Payback of less than 2 years



## Reduced Sound Levels

- ▶ Sound reduction up to 50% (3dB)
- ▶ Fans optimized to minimize sound levels and maximize efficiency
- ▶ Additional sound reducing options available

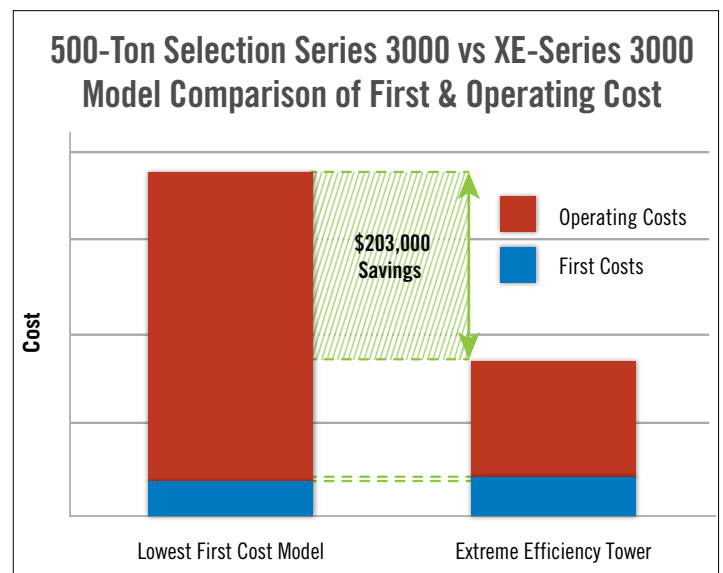

**Note:** Operating costs based on fan kW x \$0.12/kWh x 2500EFLH (equivalent full load hours) x 20 years (2011 ASHRAE Handbook HVAC Applications) x 3% per year energy inflation factor.



## Increased Operating Reliability

- ▶ BALTIDRIVE® POWER TRAIN Fan System
- ▶ Extends the life of the mechanical drive components (minimum L<sub>10</sub> bearing life 288,000 hours)
- ▶ 5-year motor and drive warranty



The XE-Series 3000 Cooling Tower



## LEED® Certification Contributions

- ▶ Industry leading energy efficiencies
- ▶ Provides energy cost savings
- ▶ Contributions to Energy and Atmosphere LEED® Credit Points (EAc1)

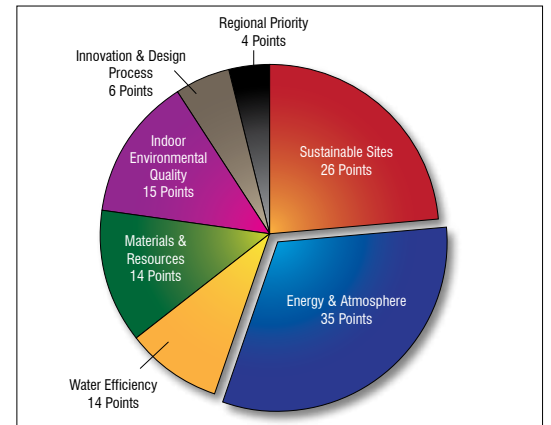

LEED® Point Breakdown for New Construction



**Lowest Operating Costs**



**Reduced Sounds Levels**



**Increased Operating Reliability**



**Contributes to LEED® Certification**

**COMPARE > SELECT > SPECIFY >**

# Series 3000 Benefits

## > Low Environmental Impact

### ▶ ENERGY EFFICIENT

- Meets or exceeds ASHRAE Standard 90.1 energy efficiency requirements
- Premium efficient/inverter duty fan motors
- Gravity distribution system with low pump head requirements

### ▶ SOUND REDUCTION OPTIONS

- Standard fan is high efficiency and low sound
- For further reduced sound levels, Low Sound Fans, Whisper Quiet Fans, and sound attenuation are available options

## > Durable Construction

- ▶ Meets wind and seismic requirements of the International Building Code (IBC)
- ▶ Designed to withstand wind loads up to 60 psf, upgraded units designed to withstand 82 psf
- ▶ Seismically verified through dynamic shake table testing up to a  $S_{Ds}$  of 3.10g
- ▶ Listed on California's Office of Statewide Health Planning and Development (OSHPD) pre-approved equipment list
- ▶ Casing panels constructed of corrosion resistant FRP with rigid frame construction
- ▶ Enhanced longevity with a variety of durable materials of construction (see **page B19** for details)

## > Reliable Year-Round Operation

- ▶ Separate air intake louvers for easy visual inspection of the air-water interface
- ▶ **BALTDRIIVE® POWER TRAIN FAN SYSTEM**
  - Backed by BAC's comprehensive 5-year motor and drive warranty
  - Corrosion resistant cast aluminum sheaves with specially designed powerband belts
  - Cooling tower duty motors designed for hostile environments



Shake Table Tested Series 3000



Durable Frame Construction



BALTDRIIVE® Power Train Fan System





## > Easy Maintenance

- ▶ Crossflow configuration provides direct access for easy maintenance
- ▶ BALTDRIIVE® Power Train uses state-of-the-art technology to ease maintenance
- ▶ Patented hygienic cold water basin is sloped at the air intakes to eliminate stagnant water and reduce biological growth
- ▶ Fill surface is elevated above the sloped cold water basin floor to facilitate flushing of dirt and debris
- ▶ Hinged access doors provide easy access to the cold water basin and fan drive system
- ▶ Combined inlet shields block sunlight, reducing the potential for algae growth in the cold water basin (option)
- ▶ Factory assembled louver face platforms, internal service platforms, and internal walkways simplify maintenance (option)



Internal Walkway and Large Access Door for Easy Maintenance

## > Easy Installation

- ▶ Rigging guides ensure proper alignment and reduce rigging time
- ▶ Flexible inlet/outlet piping connection locations ensure proper fit for any application
- ▶ Adaptable steel support configuration options, utilizing pre-existing support steel
- ▶ Knockdown units available for field assembly
- ▶ EASY CONNECT® Piping Arrangement reduces installation costs by eliminating overhead piping and piping support requirements (option)
- ▶ Basinless construction ability, ideal for installations using a common sump for multiple tower cells (option)
- ▶ Single point wiring of the fan motor and vibration cut out switch simplifies field installation when ordered with BAC Controls (option)



Factory Assembled Louver Face Platforms



Flexible Piping Arrangement

# Series 3000 Construction Details

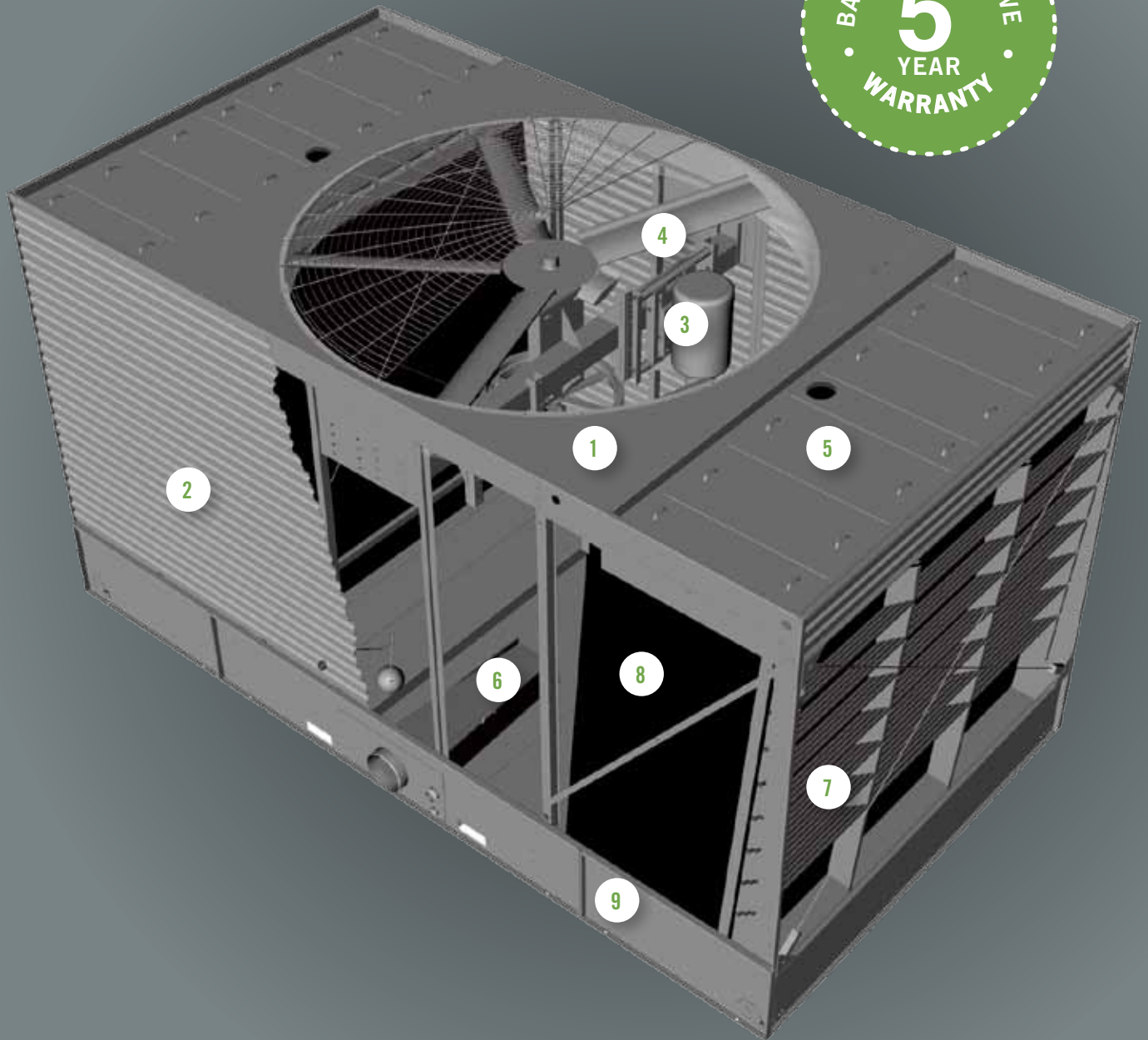

## 1 Heavy-Duty Construction

- ▶ Heavy-gauge G-235 (Z700 Metric) hot-dip galvanized steel frame
- ▶ Meets wind and seismic requirements of the International Building Code (IBC)
- ▶ Shake table tested and verified with seismic ratings up to a  $S_{Ds}$  of 3.10g
- ▶ Designed to withstand wind loads of up to 82 psf

## 2 FRP Casing Panels

- ▶ Corrosion resistant
- ▶ Maintenance free
- ▶ UV-resistant finish

## 3 BALTIDRIVE® Power Train

- ▶ Premium quality, solid backed, multi-groove belt
- ▶ Corrosion resistant cast aluminum sheaves
- ▶ Heavy-duty bearings with a minimum  $L_{10}$  of 80,000 hours
- ▶ Premium efficient, cooling tower duty motors fit for VFD applications
- ▶ 5-year motor and drive warranty

## 4 Low Horsepower Axial Fan

- ▶ Quiet operation
- ▶ High efficiency
- ▶ Corrosion resistant

## 5 Water Distribution System

- ▶ Steel covers in easy to remove sections
- ▶ Low pump head gravity distribution basins
- ▶ Large orifice, non-clog nozzles
- ▶ Weir dams provided to create even distribution that will accommodate a flow range of 50% to 100% of the design flow.

## 6 Suction Strainer

- ▶ Designed to offer optimum system protection while still offering a full 50% free area to allow efficient system pump operation
- ▶ Anti-vortexing design built into all BAC strainers
- ▶ Strainer can removed with the flip of a single latch for easy cleaning and maintenance

## 7 Air Intake Louvers

- ▶ Corrosion resistant
- ▶ Maintenance free
- ▶ UV-resistant finish

## 8 BACross® Fill with Integral Drift Eliminators

- ▶ High efficiency heat transfer surface
- ▶ Polyvinyl chloride (PVC)
- ▶ Impervious to rot, decay and biological attack
- ▶ Flame spread rating of 5 per ASTM E84
- ▶ Elevated off of the cold water basin

## 9 Hygienic Cold Water Basin

- ▶ Sloped at the air intake face to eliminate stagnant water
- ▶ Sloped toward a depressed sump for easy cleaning

## 10 Two Large Access Doors (Not Shown)

- ▶ Inward hinged door on each end wall
- ▶ Easy safe access to the interior of the unit

# Series 3000 Custom Features & Options

## > Materials of Construction

Determining the appropriate material of construction for a project depends on several factors, including water quality, climate and environmental conditions, availability of time and manpower for maintenance, unit lifetime requirements, and budget. BAC provides the widest variety of material of construction options in the industry and has the ability to provide a solution to meet all conditions and budgets. Options such as the TriArmor® Corrosion Protection System and EVERTOUGH™ Construction provide superior corrosion resistance and durability at a tremendous value.



Standard Construction Installation

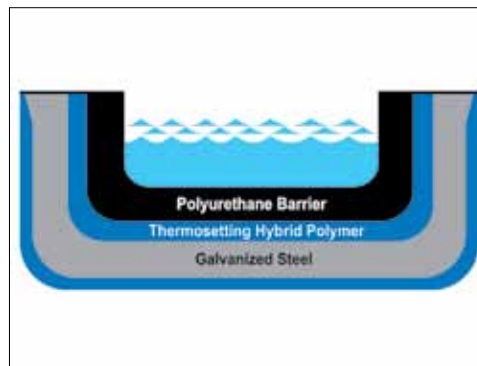

TriArmor® Corrosion Protection System Triple Layer Protection of the Cold Water Basin



### STANDARD CONSTRUCTION

G-235 mill galvanized steel is the heaviest commercially available galvanized steel, universally recognized for its strength and corrosion resistance. To assure long-life, a G-235 mill galvanized steel frame with fiberglass reinforced polyester (FRP) casing panels and louvers is used as the standard material of construction. The structural integrity of the unit is provided by its strong steel frame. Series 3000 standard construction has been seismically verified by shake table testing in an independent laboratory up to an  $S_{DS}$  of 1.40g and can withstand wind loads of up to 60 psf, proving its frame construction is designed for extreme durability. With proper maintenance and water treatment, G-235 galvanized steel and FRP will provide an excellent service life under the operating conditions normally encountered in comfort cooling and industrial applications.



### TRIARMOR® CORROSION PROTECTION SYSTEM (OPTION)

The TriArmor® Corrosion Protection System consists of heavy gauge G-235 galvanized steel panels fully encapsulated by a thermosetting hybrid polymer and further protected by a polyurethane barrier applied to all submerged surfaces of the cold water basin. The triple layers of protection form a completely seamless cold water basin for the most leak resistant and durable basin in the industry. Other components, such as the strainer, within the basin will be constructed of Type 304 Stainless Steel. The TriArmor® Corrosion Protection System was specifically designed for evaporative cooling applications and released in 2006 after a decade of extensive R&D and field testing. To date, there are over 1,000 successful installations in North America. Every basin is leak tested at the factory and warranted against leaks and corrosion for 5 years.



Application of TriArmor® Corrosion Protection System



### **EVERTOUGH™ CONSTRUCTION (OPTION)**

EVERTOUGH™ Construction combines the most corrosion resistant materials to provide the best value in corrosion protection. Specifically, a combination of the TriArmor® Corrosion Protection System, thermosetting hybrid polymer, and fiberglass reinforced polyester (FRP) casing panels and louvers are used. EVERTOUGH™ Construction units also include pultruded fiberglass reinforced polyester hot water basins, making up the most corrosion resistant construction available on the market. EVERTOUGH™ Construction is backed by a comprehensive Louver-to-Louver<sup>SM</sup> 5-year warranty, which covers ALL components from the fan to the cold water basin, from louver to louver, including the motor. A 5-year leak and corrosion warranty for the basin is also provided with the TriArmor® Corrosion Protection System.

#### ▶ **THERMOSETTING HYBRID POLYMER (OPTION)**

A thermosetting hybrid polymer, used to extend equipment life, is applied to select G-235 mill galvanized steel components of the unit. The polymerized coating is baked onto the G-235 mill galvanized steel and creates a barrier to the already corrosion resistant galvanized steel. The thermosetting hybrid polymer has been tested to withstand 6,000 hours in a 5% salt spray without blistering, chipping, or losing adhesion.

#### ▶ **STAINLESS STEEL (OPTION)**

Several Type 304 stainless steel material of construction options are available.

- **WELDED TYPE 304 STAINLESS STEEL COLD WATER BASIN**

A Type 304 welded stainless steel cold water basin is available. All steel panels and structural members of the cold water basin are constructed from Type 304 stainless steel. Seams between panels inside the cold water basin are welded, providing an advantage over bolted stainless steel cold water basins for minimizing susceptibility to leaks at basin seams. The basin is leak tested at the factory and welded seams are provided with a 5-year, leak-proof warranty.

- **STAINLESS STEEL HOT WATER BASIN**

The hot water basin and basin covers are constructed of Type 304 stainless steel.



EVERTOUGH™ Construction Installation



Welded Type 304 Stainless Steel Cold Water Basin

# Series 3000 Custom Features & Options



## JE PREMIER SERIES®

All unit structural elements and the hot and cold water basins are constructed of Type 304 stainless steel. Seams between panels inside the cold water basin are welded, providing an extreme advantage over bolted cold water basins for minimizing susceptibility to leaks at basin seams. The basin is leak tested at the factory and welded seams are provided with a 5-year leak-proof warranty. Casing panels and air intake louvers are constructed of corrosion and UV-resistant fiberglass reinforced polyester (FRP). Each cooling tower provided with the JE PREMIER SERIES® Construction is backed by a comprehensive Louver-to-Louver<sup>SM</sup> 5-year warranty, which covers ALL components from the fan to the cold water basin, from louver to louver, including the motor.



JE PREMIER SERIES® Construction

### ▶ BASINLESS UNIT CONSTRUCTION (OPTION)

The basinless unit construction option enables Series 3000 Cooling Towers to be directly installed on new or existing cold water basins. This custom feature reduces maintenance costs by eliminating the integral basin from traditional units. It simplifies piping and pumping requirements of multi-cell installations, eliminates concern for basin corrosion, and provides a cost-effective solution for many field-erected replacement projects. BAC is the only leading evaporative cooling equipment manufacturer to provide basinless construction for factory assembled equipment.



Basinless Construction

### ▶ SEISMIC/WIND UPGRADED STRUCTURE (OPTION)

Select steel panels and structural members are upgraded for higher seismic and wind load applications. An upgraded Series 3000 is certified to withstand up to an  $S_{DS}$  of 3.10g and wind loads of 82 psf. All BAC upgraded units are shake table tested by an independent laboratory to certify the most accurate seismic ratings ensuring that the unit will remain operable following a seismic event.

### ▶ STANDARD FIBERGLASS REINFORCED POLYESTER (FRP) CASING PANELS

Used with BAC's durable frame construction, FRP casing panels offer a more durable corrosion resistant unit. FRP casing panels are a key component due to their corrosion resistant properties.

### ▶ STEEL CASING PANELS AND LOUVERS (OPTION)

Steel casing panels and louvers are available in G-235 mill galvanized steel, thermosetting hybrid polymer, and stainless steel.



Seismic/Wind Upgraded Structure with Fiberglass Reinforced (FRP) Casing Panels



## › Drive System Options

The fan drive system provides the cooling air necessary to reject unwanted heat from the system to the atmosphere. All BAC drive systems use premium efficient cooling tower duty motors and include BAC's comprehensive 5-year motor and drive warranty. Cooling tower duty motors are specially designed for the harsh environment inside a cooling tower and have permanently lubricated bearings, drastically decreasing the maintenance requirement of the motor. BAC belt drive systems are the most durable and maintenance friendly drive systems on the market, including single nut adjustment for belt tensioning to make belt tensioning simple.



### STANDARD BALTIDRIVE® POWER TRAIN

The BALTIDRIVE® Power Train utilizes special corrosion resistant materials of construction and state-of-the-art technology to ensure ease of maintenance and reliable year-round performance. This BAC engineered drive system consists of a specially designed powerband and two cast aluminum sheaves located at minimal shaft centerline distances to maximize belt life. As compared to a gear drive system, this specially engineered belt drive system provides many advantages. The BALTIDRIVE® Power Train requires only periodic inspection of components and belt tensioning, which is simple with a single nut adjustment, and requires less downtime. Only fan bearing lubrication is required for routine maintenance. Belt drive systems also have the added advantage of being suitable for variable frequency drive (VFD) applications without requiring expensive optional accessories.



BALTIDRIVE® Power Train Fan System



### BALTIGUARD™ FAN SYSTEM (OPTION)

The BALTIGUARD™ Fan System consists of two standard single-speed fan motor and drive assemblies. One drive assembly is sized for full speed and load, and the other is sized approximately 2/3 speed and consumes only 1/3 the design horsepower. This configuration provides the reserve capability of a standby motor in the event of failure. As a minimum, approximately 70% capacity will be available from the low horsepower motor, even on a design wet-bulb day. Controls and wiring are the same as those required for a two-speed, two-winding motor. Redundant motors are available by increasing the size of the standby fan motor of the BALTIGUARD™ Fan System to the size of the main motor. This provides 100% motor redundancy and the greatest level of reliability.



BALTIGUARD™ Fan System Provides Built in Redundancy

# Series 3000 Custom Features & Options



## **BALTIGUARD PLUS™ FAN SYSTEM (OPTION)**

The BALTIGUARD PLUS™ Fan System builds on the advantages of the BALTIGUARD™ Fan System by adding a variable frequency drive (VFD) to either the pony or the main motor, depending on system requirements. This offers the benefits of additional capacity control and energy savings, along with the redundancy offered by the BALTIGUARD™ Fan System. Alternatively, a VFD can be added to both the pony and main motor for complete capacity control and redundancy under any load.

### ▶ **GEAR DRIVE SYSTEM, CLOSE-COUPLED MOTOR (OPTION, STANDARD ON S3E-1222-14T, S3E-1424-12T, S3E-1424-13T, AND S3E-1424-14T)**

A gear drive system is available as a fan drive option on the Series 3000. Both the gear drive and couplings are selected with a 2.0 service factor. Gear construction includes a nickel-alloy steel shaft, casehardened gears, self lubrication, and a single piece, gray iron housing. This drive system ships completely installed and aligned.

### ▶ **GEAR DRIVE SYSTEM, EXTERNALLY MOUNTED MOTOR (OPTION)**

A gear drive system with a TEFC motor mounted outside the airstream is also available on the Series 3000. A non-corrosive carbon-fiber composite drive shaft with stainless steel hubs is selected with a 2.0 service factor. The motor and drive shaft ship separately for easy field installation.

### ▶ **VIBRATION CUTOUT SWITCH (OPTION)**

A factory mounted vibration cutout switch is available to effectively protect against rotating equipment failure. BAC can provide either a mechanical or solid-state electronic vibration cutout switch in a NEMA 4 enclosure to ensure reliable protection. Additional contacts can be provided on either switch type to activate an alarm. Remote reset capability is also available on either switch type.

### ▶ **EXTENDED LUBRICATION LINES (OPTION)**

Extended lubrication lines are available for lubrication of the fan shaft bearings. Fittings are located on the exterior casing panel next to the access door.



BALTIGUARD PLUS™ Fan System  
Used for VFD Applications



Extended Lubrication Lines with  
Grease Fittings Located by the  
Access Door







## > Cold Water Basin

The cooling tower water collects in the cold water basin which provides the required head pressure for the cooling system pump. The Series 3000 cold water basin includes BAC's patented hygienic cold water basin design. During operation, BAC's patented hygienic cold water basin eliminates any stagnant water zones, which are susceptible to biological growth.

### ▶ **STANDARD MECHANICAL WATER LEVEL CONTROL**

Mechanical make-up valves must operate continuously in the moist and turbulent environment existing within evaporative cooling equipment. Due to this environment, the operation of the valve must be simple, and the valve must be durable. BAC's high quality mechanical water level control assembly is standard with all units, and has been specially designed to provide the most reliable operation while being easy to maintain. This accessory is omitted for remote sump applications.



Mechanical Water Level Control



### **ELECTRIC WATER LEVEL CONTROL (OPTION)**

BAC's Electric Water Level Control (EWLC) is a state-of-the-art conductivity actuated, probe type liquid level control. The hermetically sealed EWLC is engineered and manufactured specifically for use in evaporative cooling systems and is equipped with an error code LED which illuminates to indicate status, including when the water and/or probes are dirty. The EWLC option replaces the standard mechanical make-up valve, and includes a slow closing, solenoid activated valve in the make-up water line to minimize water hammer. EWLC is recommended when more precise water level control is required and in areas that experience sub-freezing conditions.

### ▶ **SIDE OUTLET DEPRESSED SUMP BOX (OPTION)**

A side outlet depressed sump box is available for field installation below the base of the tower. This option facilitates horizontal piping below the basin, and is a compact alternative to using an elbow in the piping arrangement, saving on both installation time and cost. The outlet connection is designed to mate with an ASME Class 150 flat face flange. See the "Connection Guide" on **page J176** for more information on standard and optional unit connection types.



Electric Water Level Control

# Series 3000 Custom Features & Options



## BASIN HEATERS (OPTION)

Evaporative cooling equipment exposed to below freezing ambient temperatures require protection to prevent freezing of the water in the cold water basin when the unit is idle. Factory-installed electric immersion heaters, which maintain 40°F (4.4°C) water temperature, are a simple and inexpensive way of providing such protection.

### HEATER kW DATA

Model Number	0°F (-17.8°C) Ambient Heaters		-20°F (-28.9°C) Ambient Heaters	
	Number of Heaters	kW per Heater	Number of Heaters	kW per Heater
S3E/S3XE-8518	2	6	2	9
S3E/S3XE-1020	2	8	2	12
S3E/S3XE-1222-06x, 1222-07x	2	10	2	14
S3E/S3XE-1222-10x, 1222-12x, 1222-13x, 1222-14x	2	12	2	15
S3E/S3XE-1424-07x	2	14	2	18
S3E/S3XE-1424-12x, 1424-13x, 1424-14x	2	14	2	20



**NOTE:** This table is based on 460V/3 phase/60 Hz power.

### ▶ STEAM COIL AND STEAM INJECTOR BASIN FREEZE PROTECTION (OPTION)

Steam coils and steam injectors are available to provide basin freeze protection (not available on units with TriArmor® Corrosion Protection System or EVERTOUGH™ Construction).

### ▶ BASIN SWEEPER PIPING (OPTION)

Basin sweeper piping is an effective method of reducing sediment that may collect in the cold water basin of the unit. A complete piping system, including nozzles, is provided in the cold water basin to connect to side stream filtration equipment (provided by others). For more information on filtration systems, consult “Filtration Guide” found on **page J233**.

### ▶ LOW AND HIGH LEVEL ALARM FLOAT SWITCHES (OPTION)

Low and high level alarm float switches are available to provide added control to your equipment operation. Level alarms can alert operators to an abnormal operating condition to ensure the highest system efficiency with minimal water usage.



Basin Heater

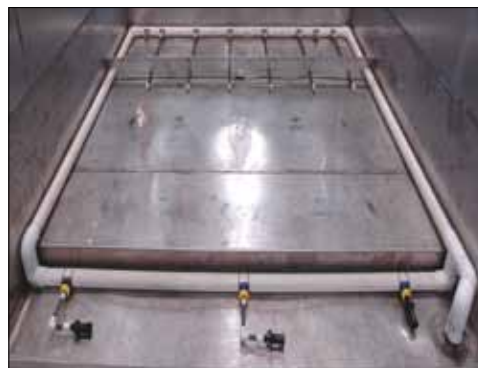

Basin Sweeper Piping



## > Multi-Cell Unit Options

Special care must be taken for multi-cell installations to ensure balanced water levels in the cold water basins across cells. If measures are not put in place to ensure balanced basin water levels, a potential exists that one basin may overflow and dump water, while the water level in another tower goes low and requires make-up. This leads to unnecessary water waste. To prevent this from occurring, BAC provides two options for balancing water levels and recommends that the installation be designed to ensure balanced flows to and from each tower.

### ▶ FLUME BOX – STANDARD ON ALL MULTI-CELL UNITS

A flume box is provided as standard for multi-cell units to balance the water level in the cold water basins. See the “Connection Guide” on **page J176** for more information.

### ▶ EQUALIZER (OPTION)

Equalizer connections are available as an option for multi-cell cooling towers in lieu of a flume box. Use of an equalizer allows for easy isolation of a cell for winter operation, maintenance, or inspection while continuing system operation. See “Cooling Towers in Parallel” on **page J167** for more information.

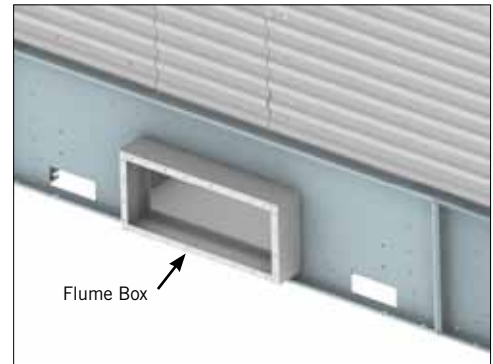

Flume Box

## > Water Distribution System

The Series 3000 Cooling Tower utilizes a low pump head gravity distribution system with large orifice non-clogging nozzles that requires less pump energy than a pressurized distribution system.

### ▶ STANDARD TOP INLET CONNECTIONS

The Series 3000 comes standard with top inlet connections to each of the hot water basins. Hot water basin covers matching the unit material of construction come in easy to handle sections for easy access and inspection of the distribution system. The use of gravity distribution minimizes pump head requirements and allows for maintenance during unit operation. BAC’s patented non-clog nozzles ensure even flow over the fill area and are simple to remove for maintenance.



Top Inlet Connections

# Series 3000 Custom Features & Options



## EASY CONNECT® PIPING ARRANGEMENT (OPTION)

The EASY CONNECT® Piping Arrangement simplifies water inlet piping on the Series 3000 by automatically balancing the flow within each cell, eliminating the need for flow balancing valves. A single water inlet connection, located on the side or bottom of each unit, eliminates the need for overhead piping and piping supports. It reduces installation costs and reduces potential for errors during field piping fabrication.



EASY CONNECT® Piping Arrangement

## STANDARD WEIR DAMS

Reducing water flow through a unit below the recommended level may potentially create uneven water distribution through the heat transfer section, causing scale build up, splash out/drift, and icing. To successfully modulate the water flow while avoiding potential complications, weir dams may be installed in the hot water basin. With a weir dam, the hot water basin can accommodate a flow range of 50% to 100% of the design flow.

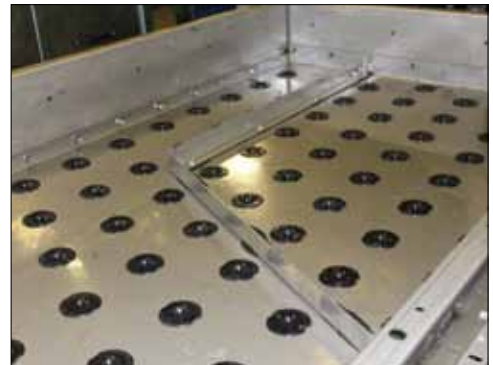

Weir Dams

## > Fill

BACross® Fill, BAC's patented crossflow hanging fill, was developed after years of extensive research. BACross® Fill is made of PVC and is optimized to provide the most efficient thermal capacity. PVC is virtually impervious to rot, decay, and biological attack. The fill is elevated above the cold water basin floor to facilitate cleaning and maintenance. The integral eliminators effectively strip entrained moisture from the leaving air stream with minimum pressure drop to prevent water loss with negligible impact on efficiency.



BACross® Fill Manufacturing



## STANDARD FILL

Standard fill can be used in applications with entering water temperature up to 130°F (54.4°C). The fill and drift eliminators are formed from self-extinguishing PVC having a flame spread rating of 5 per ASTM E84.

## ▶ HIGH TEMPERATURE FILL (OPTION)

An optional high temperature fill material is available which increases the maximum allowable entering water temperature to 140°F (60°C).



## > Capacity Enhancement

The need to enhance the capacity of a unit may be necessary when layout is restricted or if capacity requirements have increased and exceed an existing unit's capabilities. By enhancing the capacity of a unit, it may be possible to use a smaller foot print while still meeting thermal requirements of the installation.

### ▶ VELOCITY RECOVERY (VR) STACKS (OPTION)

A VR stack is a conical fan cowl extension that reduces the discharge pressure the fan has to work against, allowing the fan to move more air for the same energy input. By moving more air through the same unit, the cooling capacity is increased without increasing horsepower or footprint. Effectively, the amount of energy required for each ton of cooling capacity is reduced. VR stacks are factory assembled, CTI certified, and can be configured during initial unit purchase to reduce energy requirements or through the aftermarket to increase capacity.



Velocity Recovery (VR) Stacks

## > Shipping and Rigging

BAC units are factory-assembled to ensure uniform quality with minimum field assembly. Each unit has been designed with rigging and assembly in mind and includes features to minimize the number of tools required and installation time.

### ▶ STANDARD RIGGING GUIDES

Rigging guides allow for the upper and lower section of units with a two piece rig to align and engage. The guides ensure proper placement of the top section for multi-cell installations, making rigging much simpler and reducing the time required. This is especially critical during multi-cell installations when units are rigged side-by-side.

### ▶ KNOCKDOWN UNITS (OPTION)

Knockdown units are available for jobs where access to the cooling tower location is limited by elevators, doorways, or similar obstacles, where lifting methods impose very strict weight limits, or where the shipping cost of a fully assembled tower is excessive. All materials of construction and design features are the same as those of a factory assembled unit. Welded Type 304 stainless steel cold water basins and TriArmor® Corrosion Protection System cold water basins are excluded due to the need for in-plant assembly.



Rigging Guides Ensure Alignment



Knockdown Unit Installation

# Series 3000 Custom Features & Options

## > Sound Options

Recognition of the importance of sound reduction is growing and can be a very important design criterion for any project. BAC maintains the widest selection of sound mitigating options in the market place and can provide the most cost effective option to meet any requirement.



### **STANDARD FAN**

The fan provided for all Series 3000 Cooling Towers is selected to optimize low sound levels and maximize thermal performance.

### ▶ **LOW SOUND FAN (OPTION)**

The Low Sound Fan option reduces sound up to 9 dBA. Adding a high solidity fan decreases fan speeds, which proportionally decreases sound levels. The thermal performance with the Low Sound Fan has been certified in accordance with CTI Standard STD-201.

### ▶ **WHISPER QUIET FAN (OPTION)**

For the most extreme sound limitations, BAC's Whisper Quiet Fan reduces sound up to 19 dBA. The fiberglass reinforced polyester (FRP) fan blades have blade leading edge protection as standard. These chemical resistant, non-corrosive fans require minimal maintenance, making them well suited for use in cooling tower applications.

### ▶ **SOUND ATTENUATION (OPTION)**

Factory designed, tested, and rated sound attenuation options are available for both the air intake and discharge. Consult your local BAC Representative regarding available options.



Low Sound Fan



Whisper Quiet Fan

## > Air Intake Options

In a cooling tower, airborne debris can be entrained in the water through the unit's air intake. The Series 3000 has several options for air intake accessories that prevent debris from entering the system and maintain even unobstructed flow through the unit. Reducing the amount of debris that enters the tower lowers maintenance requirements and helps to maintain thermal efficiency.



### ▶ **STANDARD LOUVERS**

Air intake louvers matching the material of construction of the unit casing panels are standard. Scale formation and icing on the louvers and fill sheets can damage the fill and reduce thermal performance. The Series 3000 louvers are specially designed with greater spacing between louvers (12") and are completely separate from the fill section. This reduces scale and ice accumulation and allows for unobstructed air flow through the unit.



### ▶ **COMBINED INLET SHIELDS (CIS) (OPTION)**

The Combined Inlet Shields' (CIS) bent flow path blocks sunlight from the cold water basin and fill section and acts as a screen to prevent debris from entering the unit. These benefits result in a significant reduction in algae growth, debris accumulation, and scale build-up. CIS are constructed from corrosion and UV resistant PVC, are CTI certified, and are installed in easy to handle sections that are separate from the fill section to facilitate removal, inspection, and replacement. The use of CIS results in lower maintenance costs and ease of maintenance over the life of the unit.

### ▶ **AIR INTAKE SCREENS (OPTION)**

1" x 1" wire mesh screens are available factory-installed over the air intake louvers to prevent debris from entering the tower and are CTI certified.



Combined Inlet Shields (CIS)

## > **Access Options**

BAC provides a broad offering of access options. Our evaporative equipment is designed to be the most easily maintained for sustaining capacity over a longer life. All BAC platforms and ladders are OSHA compliant to ensure personnel safety and code compliance.

### ▶ **MOTOR REMOVAL SYSTEM (OPTION)**

All motor removal system options include modular davit arm(s) to facilitate motor replacement. There are three types of motor removal systems available on the Series 3000.



Motor Removal System with Davit Arm, Motor Access Platform, and Handrail Package

# Series 3000 Custom Features & Options



**NOTE:** Platforms, ladders, handrails, safety gates, and safety cages can be added at the time of order or as an aftermarket item.



## EXTERNAL PLATFORMS AND LADDER PACKAGES (OPTION)

External platforms and ladder packages (now factory assembled prior to shipping) are available to provide safe access to key components of the unit for maintenance. Multiple configurations are available, including louver face platforms to gain access to the distribution system and motor access platforms for externally mounted gear drive motors.

## ACCESS DOOR PLATFORM AND LADDER PACKAGES (OPTION)

An access door platform is available to allow access to the unit when installed on elevated supports (these are now factory assembled prior to shipping). This option allows for safe access to the unit, as well as a working platform to stage tools for maintenance.

## HANDRAIL PACKAGES (OPTION)

Handrail packages are available to provide safe access to the top of the unit for maintenance to the distribution system. Fan deck extensions are available for passage around the fan on units designed with maximized fan diameters, Velocity Recovery (VR) Stacks, or discharge sound attenuation. The specially designed handrail packages are secured for compact shipping in the cold water basin to minimize shipping costs and are ready for field assembly.



## INTERNAL WALKWAY (OPTION)

An internal walkway is available, allowing access to the spacious plenum area for maintenance and inspection of the cold water basin, make-up, fill, and drive system.

## INTERNAL SERVICE PLATFORM AND LADDER PACKAGES (OPTION FOR TWO PIECE UNITS)

For access to the motor and drive assemblies, an internal ladder and upper service platform with handrails is available on larger units. Safety gates are available for all handrail openings, and all components are designed to meet OSHA requirements. An internal walkway is required with this package.



External Ladder and Platform



External Ladder, Safety Cage, and Handrail



Internal Ladder, Service Platform, and Walkway



# Series 3000 Engineering Data



**NOTE: Do not use for construction.** Refer to factory certified dimensions. This catalog includes data current at the time of publication, which should be reconfirmed at the time of purchase. Up-to-date engineering data, free product selection software, and more can be found at [www.BaltimoreAircoil.com](http://www.BaltimoreAircoil.com).

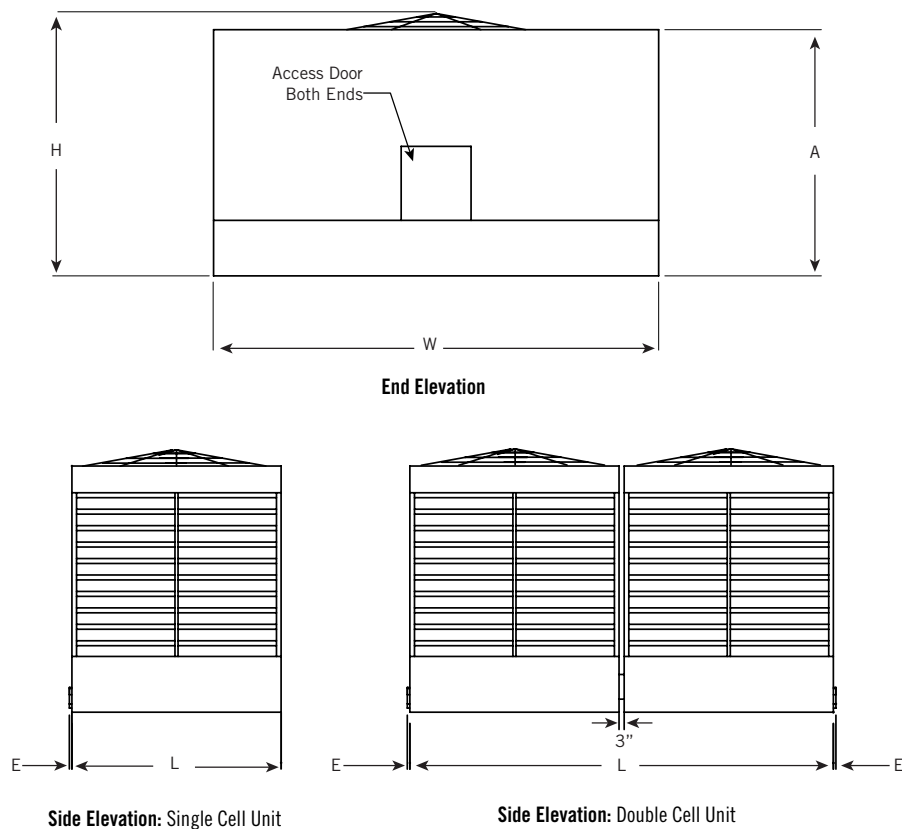

**NOTE:** The following units ship in two sections per cell. The top section is the heaviest and tallest. Top section heights are:

S3E Model	Catalog Upper Section With Installed Fan Guard Height (in)	S3E Model	Catalog Upper Section With Installed Fan Guard Height (in)
S3E-1222-10x	10'-3"	S3E-1424-13 (L to Q)	10'-5"
S3E-1222-12x	10'-3"	S3E-1424-13 (R to S)	10'-11"
S3E-1222-13x	10'-3"	S3E-1424-13 (T)	11'-3"
S3E-1222-14x	11'-7"	S3E-1424-14 (M to Q)	11'-9"
S3E-1424-12 (L to Q)	10'-5"	S3E-1424-14 (R to S)	10'-11"
S3E-1424-12 (R to S)	10'-11"	S3E-1424-14 (T)	12'-7"
S3E-1424-12 (T)	11'-3"		

# Series 3000 Single Cell Data

Model Number	Nominal Tonnage <sup>[2]</sup>	Motor HP	Fan (CFM)	Weights (lbs)			Dimensions <sup>[4]</sup>			
				Operating <sup>[3]</sup>	Shipping	Heaviest Section	L	W	H <sup>[5]</sup>	A
S3E-8518-05L	293	15	77,410	15,170	8,030	8,030	8'-6"	18'-1"	9'-10"	8'-8"
S3E-8518-05M	322	20	84,620	15,230	8,090	8,090	8'-6"	18'-1"	9'-10"	8'-8"
S3E-8518-06L	329	15	84,170	16,030	8,360	8,360	8'-6"	18'-1"	11'-2"	10'-0"
S3E-8518-06M	361	20	91,930	16,050	8,380	8,380	8'-6"	18'-1"	11'-2"	10'-0"
S3E-8518-06N	388	25	98,420	16,080	8,410	8,410	8'-6"	18'-1"	11'-2"	10'-0"
S3E-8518-06O	406	30	104,060	16,130	8,460	8,460	8'-6"	18'-1"	11'-2"	10'-0"
S3E-8518-07M	400	20	98,970	18,330	8,760	8,760	8'-6"	18'-1"	12'-6"	11'-4"
S3E-8518-07N	429	25	105,860	18,360	8,790	8,790	8'-6"	18'-1"	12'-6"	11'-4"
S3E-8518-07O	451	30	111,830	18,410	8,840	8,840	8'-6"	18'-1"	12'-6"	11'-4"
S3E-8518-07P	484	40	121,940	18,570	9,000	9,000	8'-6"	18'-1"	12'-6"	11'-4"
S3E-1020-06M	384	20	97,900	19,140	9,540	9,540	9'-10"	20'-1"	10'-10"	10'-0"
S3E-1020-06N	412	25	104,760	19,280	9,680	9,680	9'-10"	20'-1"	10'-10"	10'-0"
S3E-1020-06O	436	30	110,730	19,330	9,730	9,730	9'-10"	20'-1"	10'-10"	10'-0"
S3E-1020-07M	425	20	105,810	20,180	9,890	9,890	9'-10"	20'-1"	12'-2"	11'-4"
S3E-1020-07N	457	25	113,200	20,320	10,030	10,030	9'-10"	20'-1"	12'-2"	11'-4"
S3E-1020-07O	484	30	119,610	20,370	10,080	10,080	9'-10"	20'-1"	12'-2"	11'-4"
S3E-1020-07P	530	40	130,440	20,530	10,240	10,240	9'-10"	20'-1"	12'-2"	11'-4"
S3E-1222-06M	438	20	112,310	23,660	11,380	11,380	11'-10"	21'-7"	10'-11"	10'-0"
S3E-1222-06N	471	25	120,200	23,800	11,520	11,520	11'-10"	21'-7"	10'-11"	10'-0"
S3E-1222-06O	500	30	127,050	23,850	11,570	11,570	11'-10"	21'-7"	10'-11"	10'-0"
S3E-1222-07N	523	25	130,040	25,150	12,120	12,120	11'-10"	21'-7"	12'-3"	11'-4"
S3E-1222-07O	554	30	137,410	25,200	12,170	12,170	11'-10"	21'-7"	12'-3"	11'-4"
S3E-1222-07P	607	40	149,860	25,360	12,330	12,330	11'-10"	21'-7"	12'-3"	11'-4"
S3E-1222-07Q	652	50	160,280	25,370	12,340	12,340	11'-10"	21'-7"	12'-3"	11'-4"
S3E-1222-07R	690	60	169,320	26,130	13,100	13,100	11'-10"	21'-7"	12'-9"	11'-4"
S3E-1222-10P	757	40	180,450	33,510	15,330	9,010	11'-10"	21'-7"	16'-5"	15'-6"
S3E-1222-10Q	810	50	192,540	33,670	15,490	9,170	11'-10"	21'-7"	16'-5"	15'-6"
S3E-1222-10R	856	60	203,010	33,680	15,500	9,180	11'-10"	21'-7"	16'-5"	15'-6"
S3E-1222-10S	916	75	216,630	34,640	16,460	10,140	11'-10"	21'-7"	16'-5"	15'-6"
S3E-1222-12P	812	40	191,550	36,250	16,260	9,120	11'-10"	21'-7"	19'-1"	18'-2"
S3E-1222-12Q	869	50	204,250	36,310	16,320	9,180	11'-10"	21'-7"	19'-1"	18'-2"
S3E-1222-12R	917	60	215,250	36,520	16,530	9,390	11'-10"	21'-7"	19'-1"	18'-2"
S3E-1222-12S	981	75	229,520	37,480	17,490	10,350	11'-10"	21'-7"	19'-1"	18'-2"
S3E-1222-13P	839	40	196,980	37,170	16,720	9,120	11'-10"	21'-7"	20'-5"	19'-6"
S3E-1222-13Q	897	50	209,990	37,230	16,780	9,180	11'-10"	21'-7"	20'-5"	19'-6"
S3E-1222-13R	947	60	221,240	37,440	16,990	9,390	11'-10"	21'-7"	20'-5"	19'-6"
S3E-1222-13S	1,013	75	235,850	37,520	17,070	9,470	11'-10"	21'-7"	20'-5"	19'-6"



Model Number	Nominal Tonnage <sup>(2)</sup>	Motor HP	Fan (CFM)	Weights (lbs)			Dimensions <sup>(4)</sup>			
				Operating <sup>(3)</sup>	Shipping	Heaviest Section	L	W	H <sup>(5)</sup>	A
S3E-1222-14P	872	40	203,930	37,590	17,150	9,600	11'-10"	21'-7"	21'-9"	20'-10"
S3E-1222-14Q	933	50	217,360	37,650	17,210	9,660	11'-10"	21'-7"	21'-9"	20'-10"
S3E-1222-14R	985	60	228,970	37,810	17,370	9,820	11'-10"	21'-7"	21'-9"	20'-10"
S3E-1222-14S	1,056	75	244,030	37,890	17,450	9,900	11'-10"	21'-7"	21'-9"	20'-10"
S3E-1222-14T	1,147	100	265,000	39,810	19,370	10,990	11'-10"	21'-7"	21'-9"	20'-10"
S3E-1424-07D	621	30	154,290	34,500	16,460	16,460	14'-0"	24'-1"	12'-4"	11'-4"
S3E-1424-07P	680	40	168,280	34,660	16,620	16,620	14'-0"	24'-1"	12'-4"	11'-4"
S3E-1424-07Q	729	50	179,930	34,670	16,630	16,630	14'-0"	24'-1"	12'-4"	11'-4"
S3E-1424-07R	772	60	189,980	34,680	16,640	16,640	14'-0"	24'-1"	12'-4"	11'-4"
S3E-1424-12Q	995	50	234,340	44,480	21,640	11,900	14'-0"	24'-1"	19'-3"	18'-2"
S3E-1424-12R	1,050	60	246,760	44,640	21,800	12,060	14'-0"	24'-1"	19'-9"	18'-2"
S3E-1424-12S	1,121	75	262,860	44,690	21,850	12,110	14'-0"	24'-1"	19'-9"	18'-2"
S3E-1424-12T	1,207	100	279,550	46,610	23,770	13,200	14'-0"	24'-1"	20'-1"	18'-2"
S3E-1424-13Q	1,031	50	241,640	45,860	22,030	11,900	14'-0"	24'-1"	20'-7"	19'-6"
S3E-1424-13R	1,088	60	254,360	46,020	22,190	12,060	14'-0"	24'-1"	21'-1"	19'-6"
S3E-1424-13S	1,161	75	270,860	46,070	22,240	12,110	14'-0"	24'-1"	21'-1"	19'-6"
S3E-1424-13T	1,250	100	287,930	47,990	24,160	13,200	14'-0"	24'-1"	21'-5"	19'-6"
S3E-1424-14Q	1,075	50	250,810	47,440	22,420	12,650	14'-0"	24'-1"	21'-11"	20'-10"
S3E-1424-14R	1,134	60	263,950	47,600	22,580	12,810	14'-0"	24'-1"	22'-5"	20'-10"
S3E-1424-14S	1,215	75	280,990	47,650	22,630	12,860	14'-0"	24'-1"	22'-5"	20'-10"
S3E-1424-14T	1,303	100	298,560	49,570	24,550	13,950	14'-0"	24'-1"	22'-9"	20'-10"



#### NOTES FOR SINGLE CELL UNITS:

- S3E-1222-14T, S3E-1424-12T, S3E-1424-13T and S3E-1424-14T are supplied with a gear drive system as standard.
- Nominal tons of cooling represents the capability to cool 3 USGPM of water from a 95°F entering water temperature to an 85°F leaving water temperature at a 78°F entering wet-bulb temperature.
- Operating weight is based on the water level in the cold water basin at overflow height. If a lower operating weight is needed to meet design requirements, your local BAC Representative can provide additional assistance.
- Refer to **page B32** for dimensional reference drawings.
- Models shipped with an optional gear drive or Low Sound Fan may have heights up to 10.5" greater than shown. For units with Whisper Quiet Fans please contact your local BAC Representative for accurate height dimensions.

**Do not use for construction.** Refer to factory certified dimensions. This catalog includes data current at the time of publication, which should be reconfirmed at the time of purchase.

# XE-Series Data

Model Number	Nominal Tonnage <sup>(2)</sup>	Motor HP	Fan (CFM)	Weights (lbs)			Dimensions <sup>(4)</sup>			
				Operating <sup>(3)</sup>	Shipping	Heaviest Section	L	W	H <sup>(5)</sup>	A
XES3E-8518-05G	171	3	46,830	15,000	7,860	7,860	8'-6"	18'-1"	9'-10"	8'-8"
XES3E-8518-05H	203	5	54,950	15,010	7,870	7,870	8'-6"	18'-1"	9'-10"	8'-8"
XES3E-8518-05J	233	7.5	62,370	15,040	7,900	7,900	8'-6"	18'-1"	9'-10"	8'-8"
XES3E-8518-05K	256	10	68,230	15,050	7,910	7,910	8'-6"	18'-1"	9'-10"	8'-8"
XES3E-8518-06G	194	3	51,200	15,910	8,240	8,240	8'-6"	18'-1"	11'-2"	10'-0"
XES3E-8518-06H	230	5	60,000	15,920	8,250	8,250	8'-6"	18'-1"	11'-2"	10'-0"
XES3E-8518-06J	262	7.5	68,010	15,950	8,280	8,280	8'-6"	18'-1"	11'-2"	10'-0"
XES3E-8518-06K	288	10	74,310	15,960	8,290	8,290	8'-6"	18'-1"	11'-2"	10'-0"
XES3E-8518-07G	216	3	55,510	18,190	8,620	8,620	8'-6"	18'-1"	12'-6"	11'-4"
XES3E-8518-07H	256	5	64,950	18,200	8,630	8,630	8'-6"	18'-1"	12'-6"	11'-4"
XES3E-8518-07J	292	7.5	73,520	18,230	8,660	8,660	8'-6"	18'-1"	12'-6"	11'-4"
XES3E-8518-07K	320	10	80,250	18,240	8,670	8,670	8'-6"	18'-1"	12'-6"	11'-4"
XES3E-8518-07L	365	15	90,740	18,310	8,740	8,740	8'-6"	18'-1"	12'-6"	11'-4"
XES3E-1020-06G	206	3	54,620	19,020	9,420	9,420	9'-10"	20'-1"	10'-10"	10'-0"
XES3E-1020-06H	244	5	64,020	19,030	9,430	9,430	9'-10"	20'-1"	10'-10"	10'-0"
XES3E-1020-06J	279	7.5	72,540	19,040	9,440	9,440	9'-10"	20'-1"	10'-10"	10'-0"
XES3E-1020-06K	307	10	79,230	19,050	9,450	9,450	9'-10"	20'-1"	10'-10"	10'-0"
XES3E-1020-06L	350	15	89,680	19,120	9,520	9,520	9'-10"	20'-1"	10'-10"	10'-0"
XES3E-1020-07G	228	3	59,110	20,040	9,750	9,750	9'-10"	20'-1"	12'-2"	11'-4"
XES3E-1020-07H	271	5	69,240	20,050	9,760	9,760	9'-10"	20'-1"	12'-2"	11'-4"
XES3E-1020-07J	310	7.5	78,450	20,080	9,790	9,790	9'-10"	20'-1"	12'-2"	11'-4"
XES3E-1020-07K	340	10	85,680	20,090	9,800	9,800	9'-10"	20'-1"	12'-2"	11'-4"
XES3E-1020-07L	388	15	96,960	20,160	9,870	9,870	9'-10"	20'-1"	12'-2"	11'-4"
XES3E-1222-06H	279	5	73,400	23,530	11,250	11,250	11'-10"	21'-7"	10'-11"	10'-0"
XES3E-1222-06J	318	7.5	83,170	23,560	11,280	11,280	11'-10"	21'-7"	10'-11"	10'-0"
XES3E-1222-06K	350	10	90,860	23,570	11,290	11,290	11'-10"	21'-7"	10'-11"	10'-0"
XES3E-1222-06L	399	15	102,870	23,640	11,360	11,360	11'-10"	21'-7"	10'-11"	10'-0"
XES3E-1222-07J	354	7.5	90,050	24,910	11,880	11,880	11'-10"	21'-7"	12'-3"	11'-4"
XES3E-1222-07K	389	10	98,370	24,920	11,890	11,890	11'-10"	21'-7"	12'-3"	11'-4"
XES3E-1222-07L	444	15	111,350	24,990	11,960	11,960	11'-10"	21'-7"	12'-3"	11'-4"
XES3E-1222-07M	487	20	121,530	25,010	11,980	11,980	11'-10"	21'-7"	12'-3"	11'-4"
XES3E-1222-10K	491	10	120,030	33,090	14,910	8,590	11'-10"	21'-7"	16'-5"	15'-6"
XES3E-1222-10L	559	15	135,400	33,160	14,980	8,660	11'-10"	21'-7"	16'-5"	15'-6"
XES3E-1222-10M	611	20	147,380	33,180	15,000	8,680	11'-10"	21'-7"	16'-5"	15'-6"
XES3E-1222-10N	655	25	157,340	33,320	15,140	8,820	11'-10"	21'-7"	16'-5"	15'-6"
XES3E-1222-10O	693	30	165,950	33,370	15,190	8,870	11'-10"	21'-7"	16'-5"	15'-6"
XES3E-1222-12K	528	10	127,800	35,830	15,840	8,700	11'-10"	21'-7"	19'-1"	18'-2"
XES3E-1222-12L	600	15	144,070	35,900	15,910	8,770	11'-10"	21'-7"	19'-1"	18'-2"
XES3E-1222-12M	657	20	156,730	35,920	15,930	8,790	11'-10"	21'-7"	19'-1"	18'-2"
XES3E-1222-12N	703	25	167,230	36,060	16,070	8,930	11'-10"	21'-7"	19'-1"	18'-2"
XES3E-1222-12O	744	30	176,300	36,110	16,120	8,980	11'-10"	21'-7"	19'-1"	18'-2"

Model Number	Nominal Tonnage <sup>(2)</sup>	Motor HP	Fan (CFM)	Weights (lbs)			Dimensions <sup>(4)</sup>			
				Operating <sup>(3)</sup>	Shipping	Heaviest Section	L	W	H <sup>(5)</sup>	A
XES3E-1222-13K	545	10	131,530	36,750	16,300	8,700	11'-10"	21'-7"	20'-5"	19'-6"
XES3E-1222-13L	620	15	148,260	36,820	16,370	8,770	11'-10"	21'-7"	20'-5"	19'-6"
XES3E-1222-13M	678	20	161,250	36,840	16,390	8,790	11'-10"	21'-7"	20'-5"	19'-6"
XES3E-1222-13N	727	25	172,040	36,980	16,530	8,930	11'-10"	21'-7"	20'-5"	19'-6"
XES3E-1222-13O	769	30	181,340	37,030	16,580	8,980	11'-10"	21'-7"	20'-5"	19'-6"
XES3E-1222-14L	645	15	153,570	37,240	16,800	9,250	11'-10"	21'-7"	21'-9"	20'-10"
XES3E-1222-14M	706	20	167,020	37,260	16,820	9,270	11'-10"	21'-7"	21'-9"	20'-10"
XES3E-1222-14N	756	25	178,170	37,400	16,960	9,410	11'-10"	21'-7"	21'-9"	20'-10"
XES3E-1222-14O	799	30	187,780	37,450	17,010	9,460	11'-10"	21'-7"	21'-9"	20'-10"
XES3E-1424-07J	396	7.5	101,080	34,210	16,170	16,170	14'-0"	24'-1"	12'-4"	11'-4"
XES3E-1424-07K	435	10	110,430	34,220	16,180	16,180	14'-0"	24'-1"	12'-4"	11'-4"
XES3E-1424-07L	497	15	125,010	34,290	16,250	16,250	14'-0"	24'-1"	12'-4"	11'-4"
XES3E-1424-07M	545	20	136,450	34,310	16,270	16,270	14'-0"	24'-1"	12'-4"	11'-4"
XES3E-1424-07N	585	25	146,010	34,450	16,410	16,410	14'-0"	24'-1"	12'-4"	11'-4"
XES3E-1424-12L	691	15	166,130	44,070	21,230	11,490	14'-0"	24'-1"	19'-3"	18'-2"
XES3E-1424-12M	755	20	180,510	44,090	21,250	11,510	14'-0"	24'-1"	19'-3"	18'-2"
XES3E-1424-12N	808	25	192,440	44,230	21,390	11,650	14'-0"	24'-1"	19'-3"	18'-2"
XES3E-1424-12O	854	30	202,710	44,280	21,440	11,700	14'-0"	24'-1"	19'-3"	18'-2"
XES3E-1424-12P	931	40	219,990	44,420	21,580	11,840	14'-0"	24'-1"	19'-3"	18'-2"
XES3E-1424-13L	717	15	171,590	45,450	21,620	11,490	14'-0"	24'-1"	20'-7"	19'-6"
XES3E-1424-13M	783	20	186,380	45,470	21,640	11,510	14'-0"	24'-1"	20'-7"	19'-6"
XES3E-1424-13N	838	25	198,630	45,610	21,780	11,650	14'-0"	24'-1"	20'-7"	19'-6"
XES3E-1424-13O	885	30	209,190	45,660	21,830	11,700	14'-0"	24'-1"	20'-7"	19'-6"
XES3E-1424-13P	965	40	226,910	45,800	21,970	11,840	14'-0"	24'-1"	20'-7"	19'-6"
XES3E-1424-14M	817	20	193,670	47,050	22,030	12,260	14'-0"	24'-1"	21'-11"	20'-10"
XES3E-1424-14N	874	25	206,360	47,190	22,170	12,400	14'-0"	24'-1"	21'-11"	20'-10"
XES3E-1424-14O	924	30	217,270	47,240	22,220	12,450	14'-0"	24'-1"	21'-11"	20'-10"
XES3E-1424-14P	1,007	40	235,600	47,380	22,360	12,590	14'-0"	24'-1"	21'-11"	20'-10"



#### NOTES FOR XE-SERIES UNITS:

- Nominal tons of cooling represents the capability to cool 3 USGPM of water from a 95°F entering water temperature to an 85°F leaving water temperature at a 78°F entering wet-bulb temperature.
- Operating weight is based on the water level in the cold water basin at overflow height. If a lower operating weight is needed to meet design requirements, your local BAC Representative can provide additional assistance.
- Refer to **page B32** for dimensional reference drawings.
- Models shipped with an optional gear drive or Low Sound Fan may have heights up to 10.5" greater than shown. For units with Whisper Quiet Fans please contact your local BAC Representative for accurate height dimensions.

**Do not use for construction.** Refer to factory certified dimensions. This catalog includes data current at the time of publication, which should be reconfirmed at the time of purchase.

# Series 3000 Double Cell Unit Data

Model Number	Nominal Tonnage <sup>[2]</sup>	Motor HP	Fan (CFM)	Weights (lbs)			Dimensions <sup>[4]</sup>			
				Operating <sup>[3]</sup>	Shipping	Heaviest Section	L	W	H <sup>[5]</sup>	A
S3E-8518-05L-2	585	30	154,820	30,340	16,060	8,030	17'-3"	18'-1"	9'-10"	8'-8"
S3E-8518-05M-2	643	40	169,240	30,460	16,180	8,090	17'-3"	18'-1"	9'-10"	8'-8"
S3E-8518-06L-2	658	30	168,340	32,060	16,720	8,360	17'-3"	18'-1"	11'-2"	10'-0"
S3E-8518-06M-2	723	40	183,860	32,100	16,760	8,380	17'-3"	18'-1"	11'-2"	10'-0"
S3E-8518-06N-2	776	50	196,840	32,160	16,820	8,410	17'-3"	18'-1"	11'-2"	10'-0"
S3E-8518-06O-2	813	60	208,120	32,260	16,920	8,460	17'-3"	18'-1"	11'-2"	10'-0"
S3E-8518-07M-2	800	40	197,940	36,660	17,520	8,760	17'-3"	18'-1"	12'-6"	11'-4"
S3E-8518-07N-2	858	50	211,720	36,720	17,580	8,790	17'-3"	18'-1"	12'-6"	11'-4"
S3E-8518-07O-2	903	60	223,660	36,820	17,680	8,840	17'-3"	18'-1"	12'-6"	11'-4"
S3E-8518-07P-2	968	80	243,880	37,140	18,000	9,000	17'-3"	18'-1"	12'-6"	11'-4"
S3E-1020-06M-2	767	40	195,800	38,280	19,080	9,540	19'-10"	20'-1"	10'-10"	10'-0"
S3E-1020-06N-2	823	50	209,520	38,560	19,360	9,680	19'-10"	20'-1"	10'-10"	10'-0"
S3E-1020-06O-2	872	60	221,460	38,660	19,460	9,730	19'-10"	20'-1"	10'-10"	10'-0"
S3E-1020-07M-2	851	40	211,620	40,360	19,780	9,890	19'-10"	20'-1"	12'-2"	11'-4"
S3E-1020-07N-2	913	50	226,400	40,640	20,060	10,030	19'-10"	20'-1"	12'-2"	11'-4"
S3E-1020-07O-2	968	60	239,220	40,740	20,160	10,080	19'-10"	20'-1"	12'-2"	11'-4"
S3E-1020-07P-2	1,060	80	260,880	41,060	20,480	10,240	19'-10"	20'-1"	12'-2"	11'-4"
S3E-1222-06M-2	877	40	224,620	47,320	22,760	11,380	23'-11"	21'-7"	10'-11"	10'-0"
S3E-1222-06N-2	942	50	240,400	47,600	23,040	11,520	23'-11"	21'-7"	10'-11"	10'-0"
S3E-1222-06O-2	999	60	254,100	47,700	23,140	11,570	23'-11"	21'-7"	10'-11"	10'-0"
S3E-1222-07N-2	1,046	50	260,080	50,300	24,240	12,120	23'-11"	21'-7"	12'-3"	11'-4"
S3E-1222-07O-2	1,109	60	274,820	50,400	24,340	12,170	23'-11"	21'-7"	12'-3"	11'-4"
S3E-1222-07P-2	1,215	80	299,720	50,720	24,660	12,330	23'-11"	21'-7"	12'-3"	11'-4"
S3E-1222-07Q-2	1,303	100	320,560	50,740	24,680	12,340	23'-11"	21'-7"	12'-3"	11'-4"
S3E-1222-07R-2	1,380	120	338,640	52,260	26,200	13,100	23'-11"	21'-7"	12'-9"	11'-4"
S3E-1222-10P-2	1,514	80	360,900	67,020	30,660	9,010	23'-11"	21'-7"	16'-5"	15'-6"
S3E-1222-10Q-2	1,621	100	385,080	67,340	30,980	9,170	23'-11"	21'-7"	16'-5"	15'-6"
S3E-1222-10R-2	1,712	120	406,020	67,360	31,000	9,180	23'-11"	21'-7"	16'-5"	15'-6"
S3E-1222-10S-2	1,832	150	433,260	69,280	32,920	10,140	23'-11"	21'-7"	16'-5"	15'-6"
S3E-1222-12P-2	1,624	80	383,100	72,500	32,520	9,120	23'-11"	21'-7"	19'-1"	18'-2"
S3E-1222-12Q-2	1,737	100	408,500	72,620	32,640	9,180	23'-11"	21'-7"	19'-1"	18'-2"
S3E-1222-12R-2	1,835	120	430,500	73,040	33,060	9,390	23'-11"	21'-7"	19'-1"	18'-2"
S3E-1222-12S-2	1,961	150	459,040	74,960	34,980	10,350	23'-11"	21'-7"	19'-1"	18'-2"
S3E-1222-13P-2	1,678	80	393,960	74,340	33,440	9,120	23'-11"	21'-7"	20'-5"	19'-6"
S3E-1222-13Q-2	1,794	100	419,980	74,460	33,560	9,180	23'-11"	21'-7"	20'-5"	19'-6"
S3E-1222-13R-2	1,895	120	442,480	74,880	33,980	9,390	23'-11"	21'-7"	20'-5"	19'-6"
S3E-1222-13S-2	2,025	150	471,700	75,040	34,140	9,470	23'-11"	21'-7"	20'-5"	19'-6"



Model Number	Nominal Tonnage <sup>(2)</sup>	Motor HP	Fan (CFM)	Weights (lbs)			Dimensions <sup>(4)</sup>			
				Operating <sup>(3)</sup>	Shipping	Heaviest Section	L	W	H <sup>(5)</sup>	A
S3E-1222-14P-2	1,744	80	407,860	75,180	34,300	9,600	23'-11"	21'-7"	21'-9"	20'-10"
S3E-1222-14Q-2	1,866	100	434,720	75,300	34,420	9,660	23'-11"	21'-7"	21'-9"	20'-10"
S3E-1222-14R-2	1,970	120	457,940	75,620	34,740	9,820	23'-11"	21'-7"	21'-9"	20'-10"
S3E-1222-14S-2	2,112	150	488,060	75,780	34,900	9,900	23'-11"	21'-7"	21'-9"	20'-10"
S3E-1222-14T-2	2,294	200	530,000	79,620	38,740	10,990	23'-11"	21'-7"	21'-9"	20'-10"
S3E-1424-07O-2	1,241	60	308,580	69,000	32,920	16,460	28'-2"	24'-1"	12'-4"	11'-4"
S3E-1424-07P-2	1,360	80	336,560	69,320	33,240	16,620	28'-2"	24'-1"	12'-4"	11'-4"
S3E-1424-07Q-2	1,459	100	359,860	69,340	33,260	16,630	28'-2"	24'-1"	12'-4"	11'-4"
S3E-1424-07R-2	1,545	120	379,960	69,360	33,280	16,640	28'-2"	24'-1"	12'-4"	11'-4"
S3E-1424-12Q-2	1,989	100	468,680	88,960	43,280	11,900	28'-2"	24'-1"	19'-3"	18'-2"
S3E-1424-12R-2	2,099	120	493,520	89,280	43,600	12,060	28'-2"	24'-1"	19'-9"	18'-2"
S3E-1424-12S-2	2,242	150	525,720	89,380	43,700	12,110	28'-2"	24'-1"	19'-9"	18'-2"
S3E-1424-12T-2	2,414	200	559,100	93,220	47,540	13,200	28'-2"	24'-1"	20'-1"	18'-2"
S3E-1424-13Q-2	2,062	100	483,280	91,720	44,060	11,900	28'-2"	24'-1"	20'-7"	19'-6"
S3E-1424-13R-2	2,175	120	508,720	92,040	44,380	12,060	28'-2"	24'-1"	21'-1"	19'-6"
S3E-1424-13S-2	2,322	150	541,720	92,140	44,480	12,110	28'-2"	24'-1"	21'-1"	19'-6"
S3E-1424-13T-2	2,500	200	575,860	95,980	48,320	13,200	28'-2"	24'-1"	21'-5"	19'-6"
S3E-1424-14Q-2	2,150	100	501,620	94,880	44,840	12,650	28'-2"	24'-1"	21'-11"	20'-10"
S3E-1424-14R-2	2,268	120	527,900	95,200	45,160	12,810	28'-2"	24'-1"	22'-5"	20'-10"
S3E-1424-14S-2	2,431	150	561,980	95,300	45,260	12,860	28'-2"	24'-1"	22'-5"	20'-10"
S3E-1424-14T-2	2,605	200	597,120	99,140	49,100	13,950	28'-2"	24'-1"	22'-9"	20'-10"



#### NOTES FOR DOUBLE CELL UNITS:

- S3E-1222-14T, S3E-1424-12T, S3E-1424-13T and S3E-1424-14T are supplied with a gear drive system as standard.
- Nominal tons of cooling represents the capability to cool 3 USGPM of water from a 95°F entering water temperature to an 85°F leaving water temperature at a 78°F entering wet-bulb temperature.
- Operating weight is based on the water level in the cold water basin at overflow height. If a lower operating weight is needed to meet design requirements, your local BAC Representative can provide additional assistance.
- Refer to **page B32** for dimensional reference drawings.
- Models shipped with an optional gear drive or Low Sound Fan may have heights up to 10.5" greater than shown. For units with Whisper Quiet Fans please contact your local BAC Representative for accurate height dimensions.

**Do not use for construction.** Refer to factory certified dimensions. This catalog includes data current at the time of publication, which should be reconfirmed at the time of purchase.

# Series 3000 Connection Data

Model Number	Dimensions <sup>[1]</sup>				Inlet Connection Sizes <sup>[2,4]</sup>		Outlet Connection Sizes <sup>[3,4]</sup>	
	B	C	D	F	Easy Connect	Top Inlet	Outlet	Remote Sump
S3E/XES3E-8518-05x	5'-9"	3'-9"	9"	6'-6"	8"	(2) 6"	8"	10"
S3E/XES3E-8518-06x	6'-7"	3'-9"	9"	6'-6"	8"	(2) 6"	8"	10"
S3E/XES3E-8518-07x	6'-7"	3'-9"	10"	6'-6"	10"	(2) 8"	10"	12"
S3E/XES3E-1020-06x	6'-7"	3'-9"	10"	6'-9"	10"	(2) 8"	10"	12"
S3E/XES3E-1020-07x	6'-7"	3'-9"	10"	6'-9"	10"	(2) 8"	10"	12"
S3E/XES3E-1222-06x	6'-7"	4'-0"	10"	8'-8"	10"	(2) 8"	10"	12"
S3E/XES3E-1222-07x	6'-7"	4'-0"	10"	8'-8"	10"	(2) 8"	10"	14"
S3E/XES3E-1222-10x	10'-5"	4'-0"	10"	8'-8"	12"	(2) 8"	12"	16"
S3E/XES3E-1222-12x	13'-1"	4'-0"	10"	8'-8"	12"	(2) 8"	12"	16"
S3E/XES3E-1222-13x	14'-5"	4'-0"	10"	8'-8"	12"	(2) 8"	12"	18"
S3E/XES3E-1222-14x	15'-9"	4'-0"	10"	8'-8"	14"	(2) 10"	14"	20"
S3E/XES3E-1424-07x	6'-7"	4'-1"	10"	8'-10"	12"	(2) 8"	12"	16"
S3E/XES3E-1424-12x	13'-1"	4'-1"	10"	8'-10"	14"	(2) 10"	14"	20"
S3E/XES3E-1424-13x	14'-5"	4'-1"	10"	8'-10"	14"	(2) 10"	14"	20"
S3E/XES3E-1424-14x	15'-9"	4'-1"	10"	8'-10"	14"	(2) 10"	14"	20"



## NOTES FOR CONNECTION DIMENSIONS:

1. For dimension locations, see **page B40**.
2. The specific size of the inlet and outlet connection may vary with the design cooling water flow rate.
3. Unless otherwise indicated, all connections 3" and smaller are male pipe thread, and connections 4" and larger are beveled for welding and grooved to suit a mechanical coupling.
4. On double cell units, connections are the same size but are located on both ends of the unit. Refer to **page B32** for side elevation view.

**Do not use for construction.** Refer to factory certified dimensions. This catalog includes data current at the time of publication, which should be reconfirmed at the time of purchase.



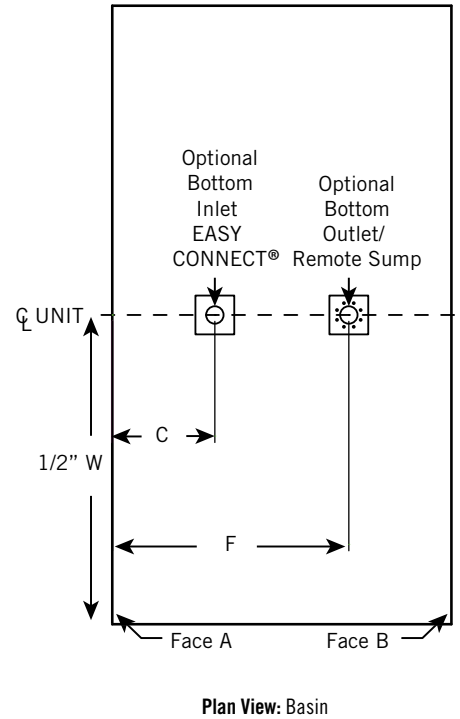
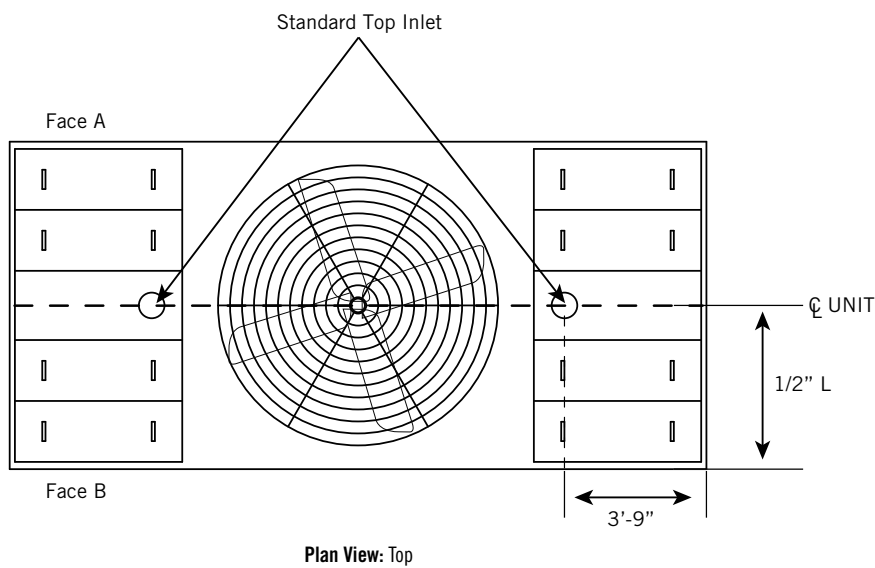
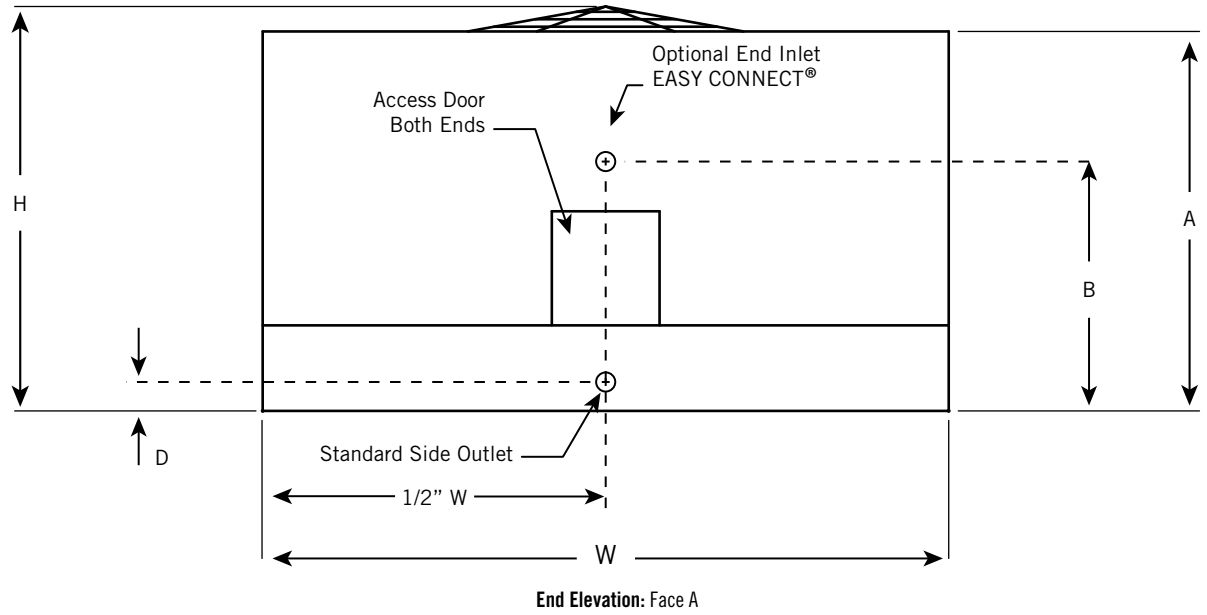

# Series 3000 Basinless Data

## CONCRETE BASIN ENGINEERING DATA FOR OPTIONAL BASINLESS UNITS

Model Number	Operating Load Vertical (lbs)	Maximum Operating Weight (lbs)	A	B	C	D
S3E/XES3E-8518-05x	1,830	10,980	9'-0 3/4"	18'-4 1/2"	9'-2 1/4"	-
S3E/XES3E-8518-06x	1,990	11,890	9'-0 3/4"	18'-4 1/2"	9'-2 1/4"	-
S3E/XES3E-8518-07x	2,390	14,320	9'-0 3/4"	18'-4 1/2"	9'-2 1/4"	-
S3E/XES3E-1020-06x	2,350	14,070	10'-5 1/4"	20'-4 1/2"	10'-2 1/4"	-
S3E/XES3E-1020-07x	2,550	15,270	10'-5 1/4"	20'-4 1/2"	10'-2 1/4"	-
S3E/XES3E-1222-06x	2,800	16,750	12'-5 3/4"	21'-10 1/2"	10'-11 1/4"	-
S3E/XES3E-1222-07x	3,180	19,030	12'-5 3/4"	21'-10 1/2"	10'-11 1/4"	-
S3E/XES3E-1222-10x	4,450	26,690	12'-5 3/4"	21'-10 1/2"	10'-11 1/4"	-
S3E/XES3E-1222-12x	4,930	29,530	12'-5 3/4"	21'-10 1/2"	10'-11 1/4"	-
S3E/XES3E-1222-13x	4,930	29,570	12'-5 3/4"	21'-10 1/2"	10'-11 1/4"	-
S3E/XES3E-1222-14x	5,320	31,870	12'-5 3/4"	21'-10 1/2"	10'-11 1/4"	-
S3E/XES3E-1424-07x	3,020	24,110	14'-7 1/8"	24'-4 1/2"	7'-8 1/4"	9'-0"
S3E/XES3E-1424-12x	4,580	36,570	14'-7 1/8"	24'-4 1/2"	7'-8 1/4"	9'-0"
S3E/XES3E-1424-13x	4,750	37,950	14'-7 1/8"	24'-4 1/2"	7'-8 1/4"	9'-0"
S3E/XES3E-1424-14x	4,950	39,530	14'-7 1/8"	24'-4 1/2"	7'-8 1/4"	9'-0"



### NOTES FOR BASINLESS DATA:

- Purchaser to design, construct, and furnish basin (including anchor bolts) in accordance with requirements given. Purchaser must also supply sump, overflow, drain, cleanout, and water make-up to suit requirements.
- All anchor bolts shall be 3/4" diameter, 1 1/2" projection ( $\pm 1/4"$ ), fully threaded. Bolt to have one nut and washer. Anchor bolt and column bearing point locations and elevations must be maintained  $\pm 1/8"$ .
- Pier dimensions shown are minimum bearing surfaces required for the tower structure and do not include corner chamfers on the concrete piers.
- Fill to be located below the operating water level (see Side View of Concrete Basin for All Models on **page B42**).
- Maximum operating weight does not include concrete basin or water retained in the basin.

**Do not use for construction.** Refer to factory certified dimensions. This catalog includes data current at the time of publication, which should be reconfirmed at the time of purchase.

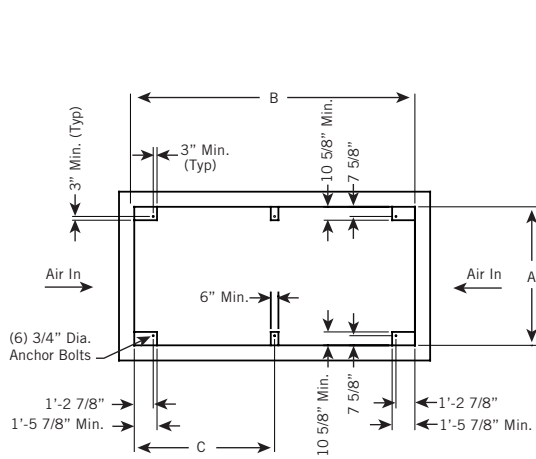

**Plan View of Concrete Basin:**  
Models S3E/XES3E-8518-X, S3E/XES3E-1020-X,  
and S3E/XES3E-1222-X

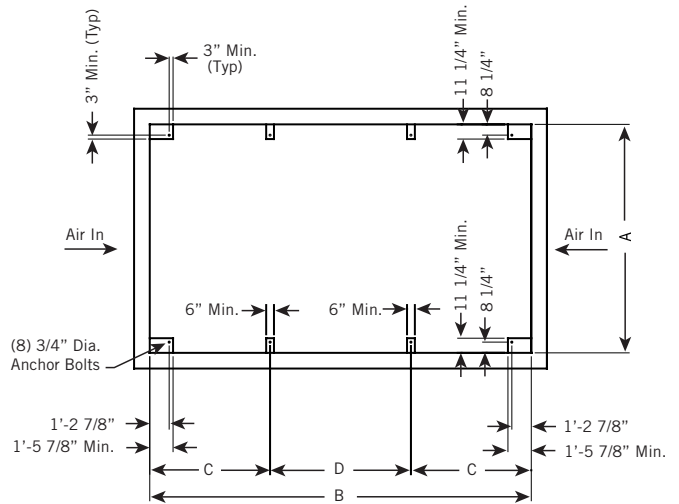

**Plan View of Concrete Basin:**  
Model S3E/XES3E-1424-X

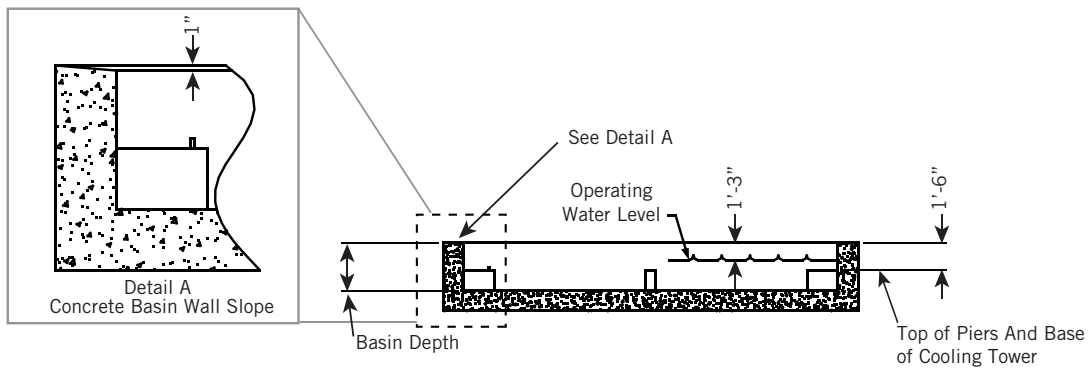

**Side View of Concrete Basin: All Models**

# Series 3000 Structural Support

The recommended support arrangement for the Series 3000 Cooling Tower consists of parallel I-beams positioned as shown in the drawings on **page B44**. Besides providing adequate support, the steel also serves to raise the unit above any solid foundation to assure access to the bottom of the tower. The Series 3000 Cooling Tower may also be supported on columns at the anchor bolt locations shown in Plan A (single cell) or Plan C (double cell). A minimum bearing surface of 12" x 12" must be provided under each of the concentrated load points. Alternate steel support arrangements can be found on **page B45**. To support a Series 3000 Cooling Tower on columns with an alternate steel support arrangement or the optional upgraded seismic and wind rated unit, consult your local BAC Representative.

## STRUCTURAL SUPPORT

Model Number	Weights (lbs)			Dimensions						
	Operating <sup>(1)</sup>	Shipping <sup>(2)</sup>	WT. at Bolt Hole Locations	L1	L2	W	A	B	C	D
S3E/XES3E-8518-05x	15,230	8,090	3,810	8'-5 3/4"	17'-2"	18'-0 1/2"	9'-4"	1 1/8"	8'-3 1/2"	4 3/4"
S3E/XES3E-8518-06x	16,130	8,460	4,040	8'-5 3/4"	17'-2"	18'-0 1/2"	9'-4"	1 1/8"	8'-3 1/2"	4 3/4"
S3E/XES3E-8518-07x	18,570	9,000	4,650	8'-5 3/4"	17'-2"	18'-0 1/2"	9'-4"	1 1/8"	8'-3 1/2"	4 3/4"
S3E/XES3E-1020-06x	19,330	9,730	4,840	9'-9 1/4"	19'-9"	20'-0 1/2"	11'-4"	1 1/8"	9'-7"	4 3/4"
S3E/XES3E-1020-07x	20,530	10,240	5,140	9'-9 1/4"	19'-9"	20'-0 1/2"	11'-4"	1 1/8"	9'-7"	4 3/4"
S3E/XES3E-1222-06x	23,850	11,570	5,970	11'-9 3/4"	23'-10"	21'-6 1/2"	12'-10"	1 1/8"	11'-7 1/2"	4 3/4"
S3E/XES3E-1222-07x	26,130	13,100	6,540	11'-9 3/4"	23'-10"	21'-6 1/2"	12'-10"	1 1/8"	11'-7 1/2"	4 3/4"
S3E/XES3E-1222-10x	34,640	16,460	8,660	11'-9 3/4"	23'-10"	21'-6 1/2"	12'-10"	1 1/8"	11'-7 1/2"	4 3/4"
S3E/XES3E-1222-12x	37,480	17,490	9,370	11'-9 3/4"	23'-10"	21'-6 1/2"	12'-10"	1 1/8"	11'-7 1/2"	4 3/4"
S3E/XES3E-1222-13x	37,520	17,070	9,380	11'-9 3/4"	23'-10"	21'-6 1/2"	12'-10"	1 1/8"	11'-7 1/2"	4 3/4"
S3E/XES3E-1222-14x	39,810	19,370	9,960	11'-9 3/4"	23'-10"	21'-6 1/2"	12'-10"	1 1/8"	11'-7 1/2"	4 3/4"
S3E/XES3E-1424-07x	34,680	16,640	8,670	13'-11 1/8"	28'-0 3/4"	24'-0 1/2"	15'-4"	1 7/16"	13'-8 1/4"	5 3/8"
S3E/XES3E-1424-12x	46,610	23,770	11,660	13'-11 1/8"	28'-0 3/4"	24'-0 1/2"	15'-4"	1 7/16"	13'-8 1/4"	5 3/8"
S3E/XES3E-1424-13x	47,990	24,160	12,000	13'-11 1/8"	28'-0 3/4"	24'-0 1/2"	15'-4"	1 7/16"	13'-8 1/4"	5 3/8"
S3E/XES3E-1424-14x	49,570	24,550	12,400	13'-11 1/8"	28'-0 3/4"	24'-0 1/2"	15'-4"	1 7/16"	13'-8 1/4"	5 3/8"



### NOTES:

1. Operating weight is based on the water level in cold water basin at overflow height.
2. Unit support beams and anchor bolts to be designed and furnished by others.
3. Support beams must be flush and level at top.
4. Steel frame members perpendicular to the support beams and under the air intake edges of unit must be at least 2" below the top of the support beams.
5. For support beam spacing other than shown, mounting holes in the unit are to be drilled by others.

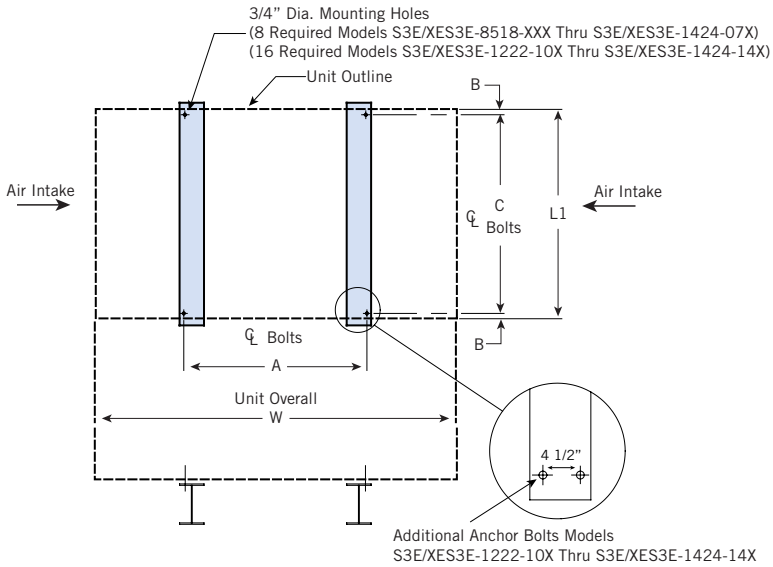

**Plan A: Single Cell Unit**

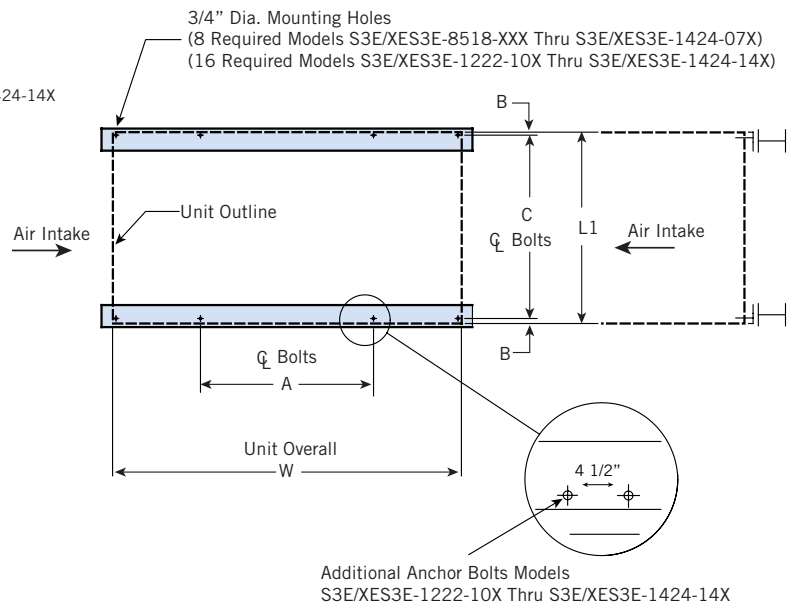

**Plan B: Single Cell Unit**

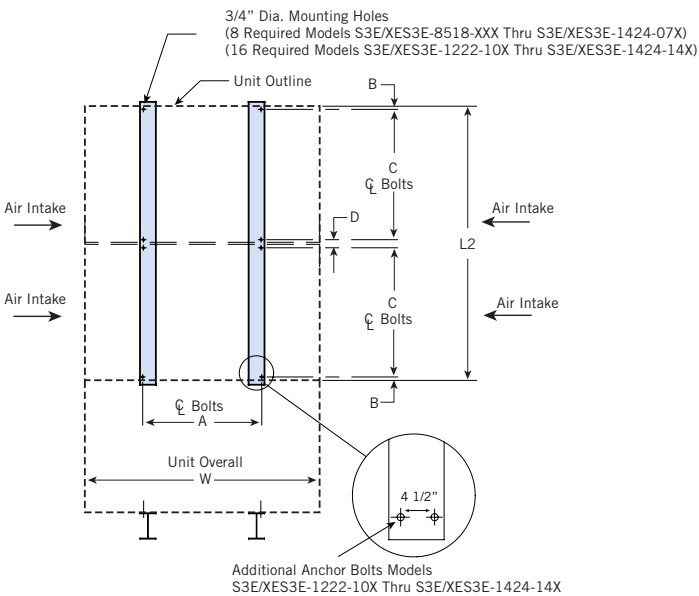

**Plan C: Double Cell Unit**

# Series 3000 Alternative Structural Support

The Series 3000 Cooling Towers (excluding basinless option) can accommodate Plan A (single cell) and Plan C (double cell) support with alternative spacing of anchor bolt hole center lines as listed in the table below. BAC provides specific anchorage drawings in the job file that reflect the revised anchor bolt hole center line dimension only. IBC wind and seismic load ratings are not available on alternate steel support arrangements. The unit will have pre-punched anchor bolt holes in the standard and minimum hole spacing locations only. All other alternative anchor bolt holes are located and drilled by others.

## ALTERNATIVE STRUCTURAL SUPPORT

Model Number	Standard Spacing "A" Dimension	Alternate Spacing "A" Dimension
S3E/XES3E-8518-X	9'-4"	7'-5"
S3E/XES3E-1020-X	11'-4"	8'-0"
S3E/XES3E-1222-X	12'-10"	9'-6"
S3E/XES3E-1424-X	15'-4"	12'-0"



**NOTE:** The standard structural support figures on **page B44** apply to alternative structural support as well.